

# TELECOM RANGE



**Model No. TEL 150F** (12 Volts, 154 Ah at 8 hour Rate to 1.75 vpc)  
Valve Regulated Lead acid Battery for communications  
standby power applications

**Innovative Features**

- ◆ Completely maintenance free, sealed construction eliminates the need for watering
- ◆ Fully tank formed plates
- ◆ Analytical Grade electrolyte
- ◆ Spill proof / leak proof
- ◆ Valve regulated Max internal pressure 2.5 psi
- ◆ Multi-position usage
- ◆ ABS Case & Cover Flame Retardant meets UL 94 VO requirements
- ◆ Low self discharge
- ◆ FAA and IATA approved as non-hazardous
- ◆ Designed to comply with Bellcore TR-NWT-000766, Bellcore TR-NWT-000909, ANSI T1.330-1997, Telcordia SR 4228, British Standard BS 6290 Part 4, IEC 896 Part 2, Eurobat, DIN 43534
- ◆ UL Recognized, ISO 9001

**Ampere Hour Capacity at 77°F (25°C) to 1.75 vpc**

Discharge Time in Hrs	1	2	3	4	5	6	7	8	10
Ampere Hour Capacity	106.0	118.0	129.0	136.0	142.0	147.0	151.0	154.0	158.0

Website: [www.hazebattery.com/usa](http://www.hazebattery.com/usa)  
E mail : [customerservice@hazebattery.com](mailto:customerservice@hazebattery.com)  
Ph: 952-746-7528 Fax: 952-746-7527



AGM Range  
Sealed Lead Acid 12 Volt Bloc

## Specifications

Nominal Voltage		12V	
Nominal Capacity		166 Ah	C20
Dimensions	Total Height (Inc terminals)	11.34 inches n/a	288 mm n/a
	Length	21.65 inches	550 mm
	Width	4.29 inches	109 mm
	Weight	106.74 lbs	48.3 Kg



Haze Battery Company Ltd

## Characteristics

Capacity 77°F (25°C) to 1.75 vpc	20 hour rate	166 Ah
	10 hour rate	158 Ah
	5 hour rate	142 Ah
	2 hour rate	118 Ah
	1 hour rate	106 Ah
Internal Resistance		3.2 mOhms
Capacity correction for temperature Variations (C20)	104°F (40°C)	102%
	68°F (20°C)	100%
	32°F (0°C)	85%
	5°F (-15°C)	65%
Self Discharge 77°F (25°C)	Capacity after 1 month storage	98%
	Capacity after 3 months storage	94%
	Capacity after 6 months storage	86%
Max Charge Current 68°F (20°C)	40	
Terminal	Standard	16mm Insert M6 thread
Charging (Constant Voltage)	Cyclic	2.40 vpc (59 -77°F)
	Float	2.27 - 2.30 vpc (59 -77°F)

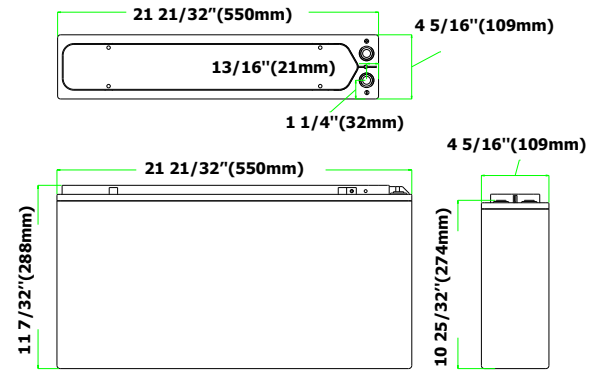

End V per Cell	Ampere Hour at 77°F (25°C)										
	1 hr	2 hr	3 hr	4 hr	5 hr	6 hr	7 hr	8 hr	10 hr	12 hr	20 hr
1.85	99.0	113.0	123.0	129.0	135.0	140.0	144.0	147.0	152.0	154.0	158.0
1.80	104.0	117.0	127.0	134.0	139.0	144.0	149.0	152.0	156.0	158.0	164.0
1.75	106.0	118.0	129.0	136.0	142.0	147.0	151.0	154.0	158.0	161.0	166.0
1.70	107.0	120.0	130.0	137.0	143.0	148.0	152.0	155.0	160.0	163.0	168.0

End V per Cell	Constant Amps Discharge - Amps at 77°F (25°C)										
	1 hr	2 hr	3 hr	4 hr	5 hr	6 hr	7 hr	8 hr	10 hr	12 hr	20 hr
1.85	99.00	56.70	40.90	32.30	27.00	23.30	20.60	18.30	15.20	12.80	7.91
1.80	104.00	58.50	42.30	33.40	27.90	24.10	21.20	18.90	15.60	13.20	8.19
1.75	106.00	59.20	43.00	34.00	28.40	24.50	21.50	19.10	15.80	13.40	8.30

## Specifications

Design Life	12 Years
Operating Temperature	-4 °F to 122 °F
Grid alloy	Calcium / Tin lead alloy
Plates	Flat Pasted
Separator	Absorbant Glass Mat
Active material	Very high purity lead
Charge Voltage	Float 2.25 - 2.30 VPC @77 °F Cychling 2.35 @77 °F Max. 2.4 VPC Max ripple 0.05C (A)
Electrolyte	Sulphuric acid Analytical grade purity
Venting Valve	EPDM Rubber 1.5 to 2 psi (10.5 - 14 KPa) release pressure. Resealing at 1 psi (7 KPa)
Torque setting	The recommended torque value for all types is 44-62 inch-pounds

## Terminal Details

Insert are made from brass with copper, nickel and silver plating giving excellent mechanical, electrical and corrosion resistant properties.

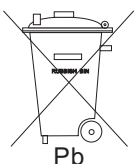

Haze Battery Company keenly encourages environmental awareness; PLEASE follow guidelines for the recycling /disposal of lead.



UL Recognised  
Component  
MH 20947

